

UNLESS OTHERWISE SPECIFIED

MACHINING - 500mm AND BELOW ±0.25mm ; ABOVE 500mm ±0.50mm

STRUCTURAL - 150mm AND BELOW ±1.0mm ; ABOVE 150mm ±1.5mm

CASTINGS - 300mm AND BELOW ±1.5mm ; ABOVE 300mm ±3.0mm

ANGULAR - ±0.5°

Drawing features to be interpreted as per AS1100.201-1992

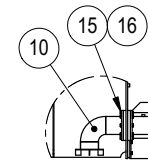
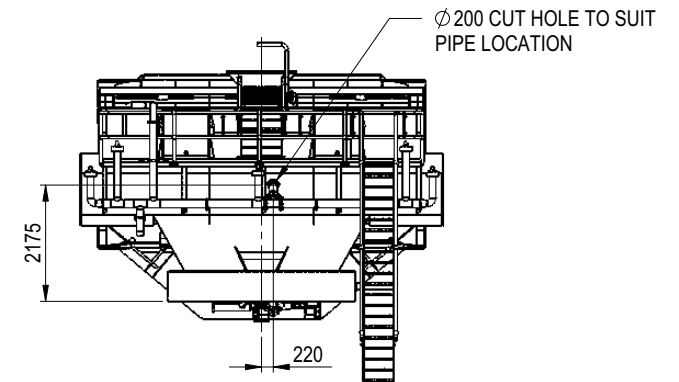
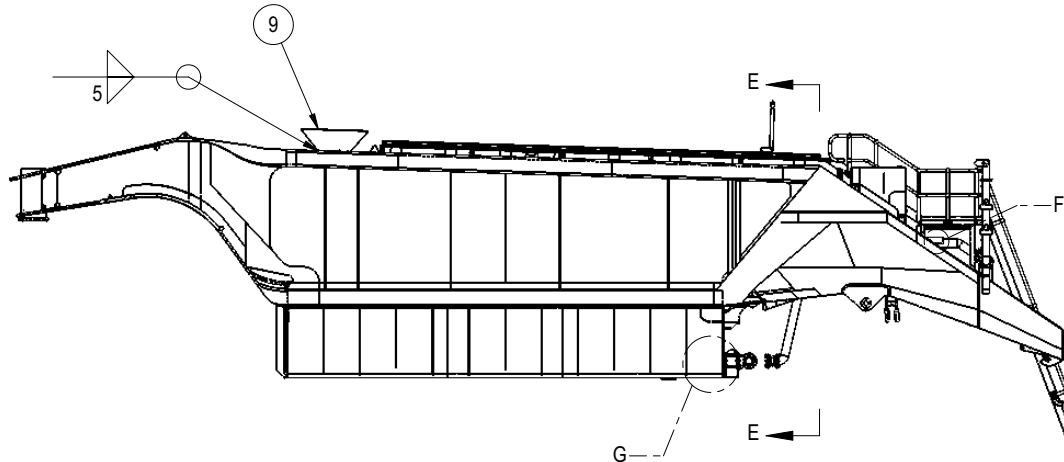
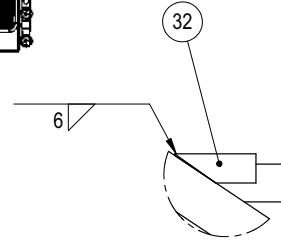
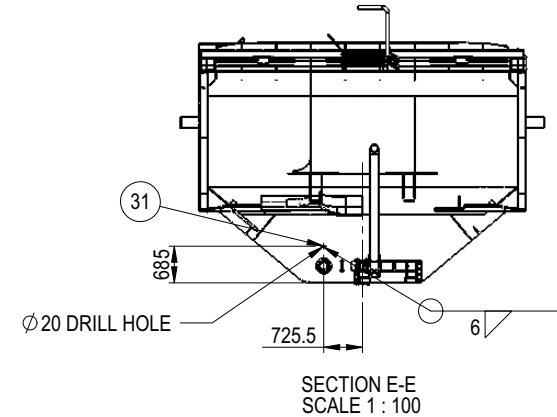
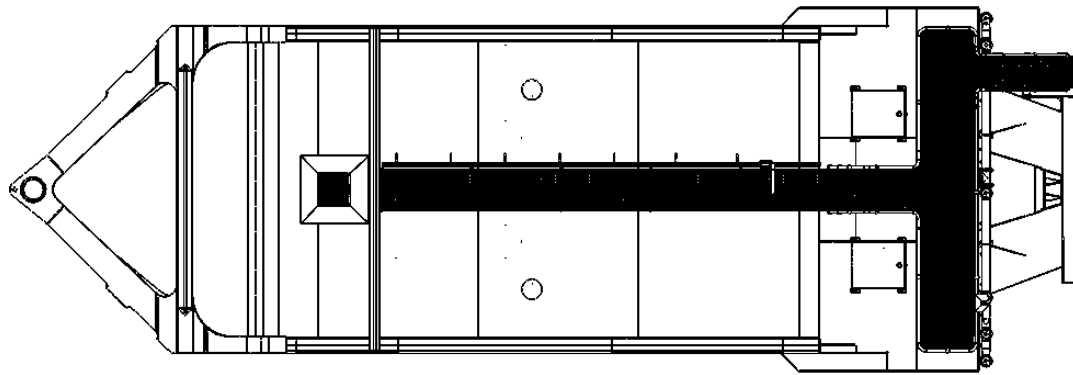

KADOR ENGINEERING (AUST.) PTY LTD
ABN: 41 010 145 534

REVISIONS	No.	BY	DATE	DESCRIPTION
		A	JTL	09.04.08

CLIENT
KADOR PTY LTD

PROJECT
190ki WATER TANK

CMP ENGINEERS
MECHANICAL ENGINEERING CONSULTANTS

BRISBANE AUSTRALIA ph. 07 3839 2045
www.cmpeng.com.au ABN 62 010 981 192

SCALE	1:1 UNO	
ENG.	MWP	07.03.08
DRAWN	JTL	07.03.08
CHECKED	IRV	09.04.08

2045 - G01 STRUCTURE	
TANK ASSY - PLUMBING/MISC	
DRAWING NUMBER	2045-01004
SHEET	3 of 3
REV	A

THE INFORMATION HEREON IS THE PROPERTY OF CMP ENGINEERS PTY LTD ANY COPYING, TRANSMITTAL TO OTHERS, AND ANY USE EXCEPT THAT FOR WHICH IT IS LOANED IS PROHIBITED, WITHOUT WRITTEN PERMISSION.