

72,000L WATER TANK  
(CONCEPTUAL CONFIGURATION)

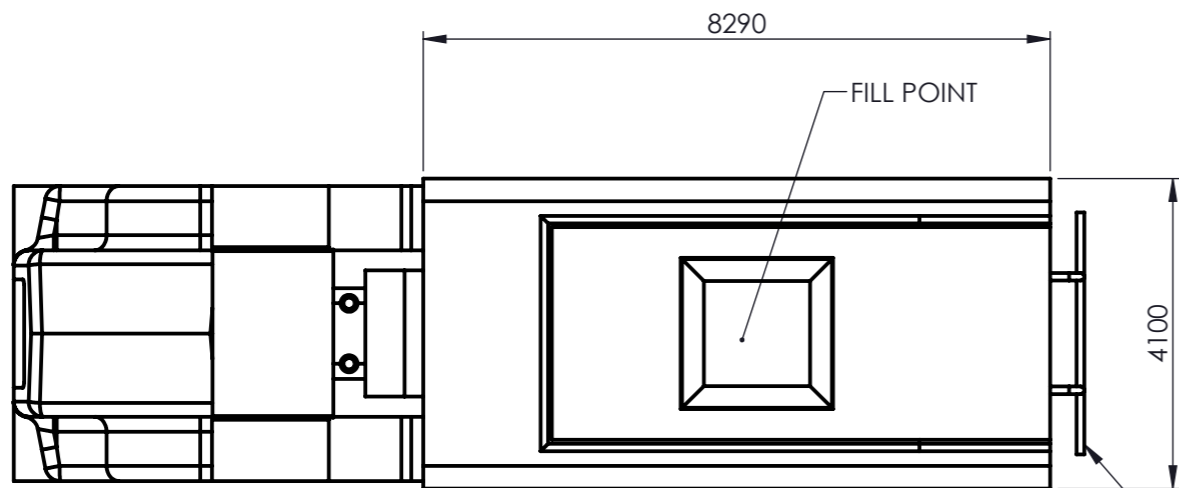

TOP VIEW

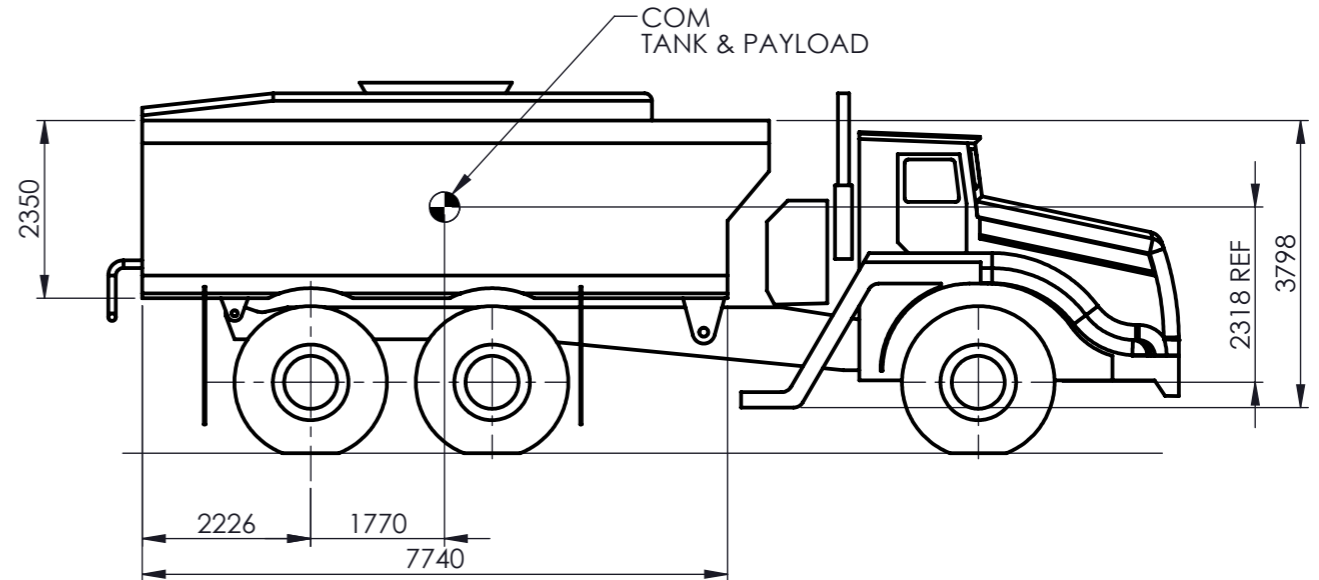

RIGHT SIDE VIEW

SPRAY BAR WITH 3 SPRAY HEADS

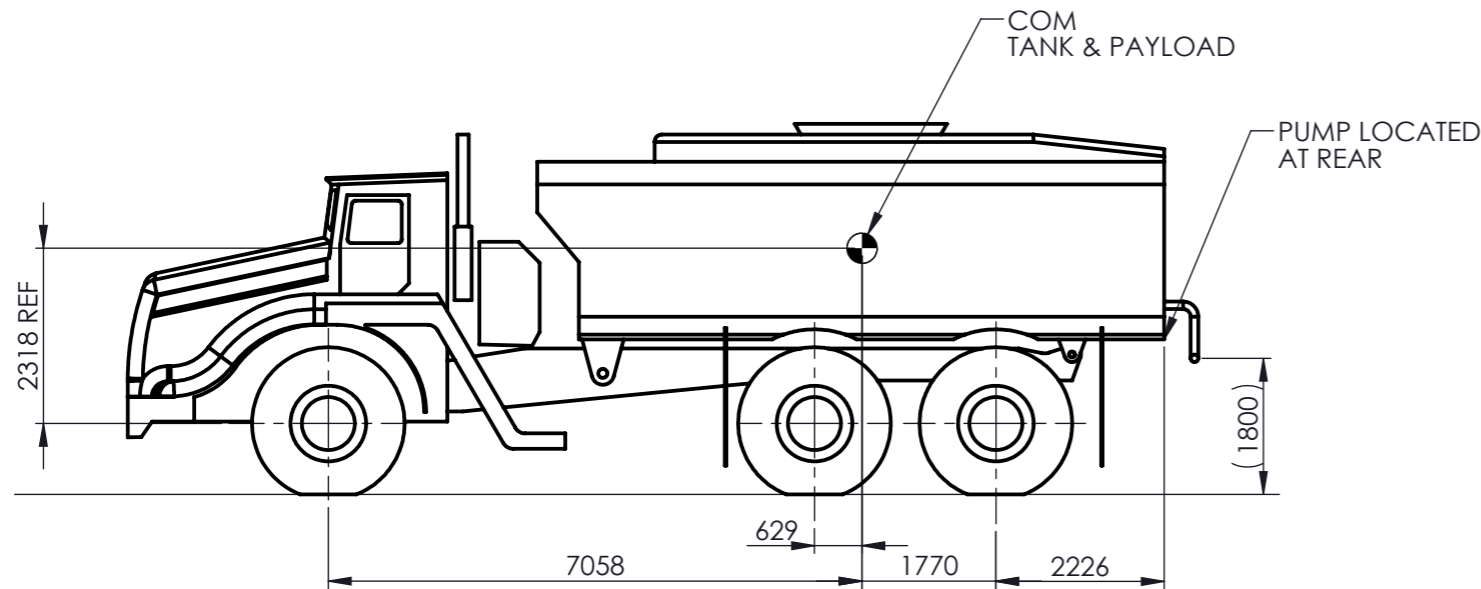

LEFT SIDE VIEW

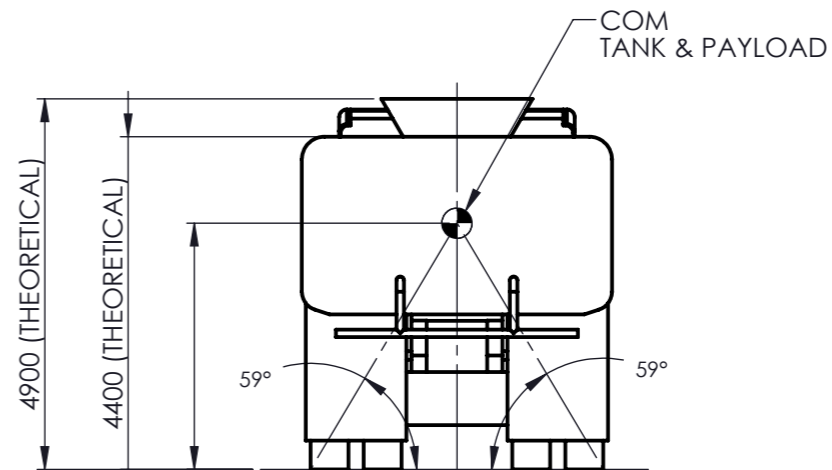

REAR VIEW

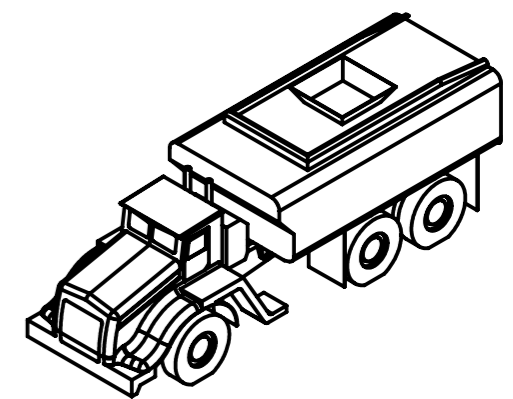

ISOMETRIC VIEW

- NOTES:
- CAPACITY OPTIONS BETWEEN 65KL - 72KL
  - QUANTITIES AND DIMENSIONS SHOWN ARE ESTIMATES ONLY AND ARE SUBJECT TO CONFIRMATION
  - PUMP AND PIPE WORK NOT SHOWN
  - SITE SPECIFIC STABILITY ASSESMENT REQUIRED

B	DAM	AMENDED FOR OPTIONAL CAPACITY RANGE	29/05/2012
A	PED	INITIAL DESIGN	7/10/2011
REV.	BY	DESCRIPTION	DATE
DRAWING REVISION HISTORY			

**FOR INFORMATION**

**DO NOT SCALE DRAWING**

STANDARD FILLET WELD SIZES FOR PLATE JOINTS - UNO	PLATE	FILLET LEG
THINNEST PLATE IN JOINT DETERMINES FILLET SIZE	6 PLT	5mm
	8 PLT	6mm
	10 PLT	8mm
	12 PLT	10mm
	16 PLT	12mm
	20 PLT	16mm
	25 PLT	16mm
	32 PLT	20mm
	40 PLT	20mm
	50 PLT	25mm

UNLESS OTHERWISE SPECIFIED: DIMENSIONS ARE IN MILLIMETERS		
TOLERANCES:	MACH:	FAB:
UP TO 150:	± 0.1	± 0.5
ABOVE 150 UP TO 300:	± 0.25	± 1.0
ABOVE 300 UP TO 1000:	± 0.5	± 1.5
ABOVE 1000:	± 1.0	± 2.5
WEIGHT	kg	
FINISH		
MATERIAL		

DRAWN	PED	7/10/2011
CHECKED	-	-
APPROVED	-	-



DESCRIPTION  
**HAULMAX 3900G - WATER TRUCK - GENERAL ARRANGEMENT**

Drawing Number **3774-100-00-GA**

SHEET  
1 OF 1  
LC PROJECT NO.  
3774  
A3  
REV  
B