

ISOMETRIC VIEW

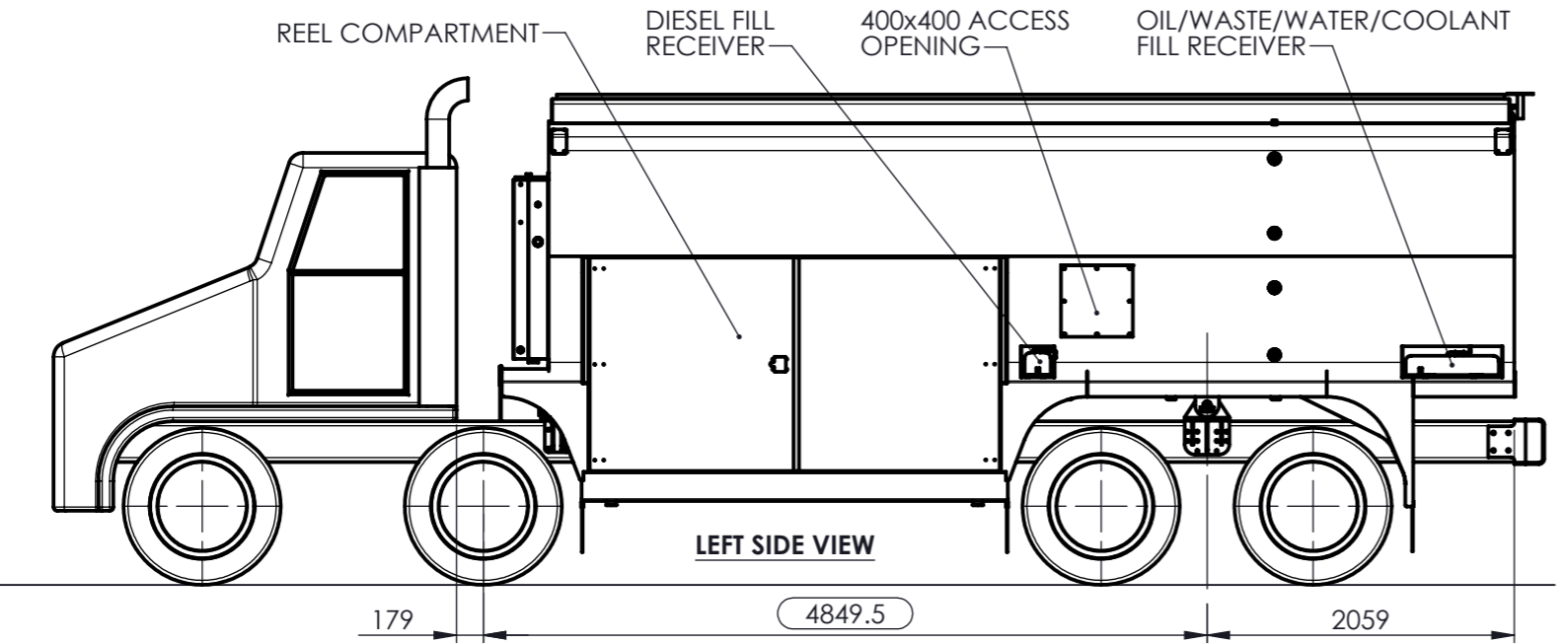

LEFT SIDE VIEW

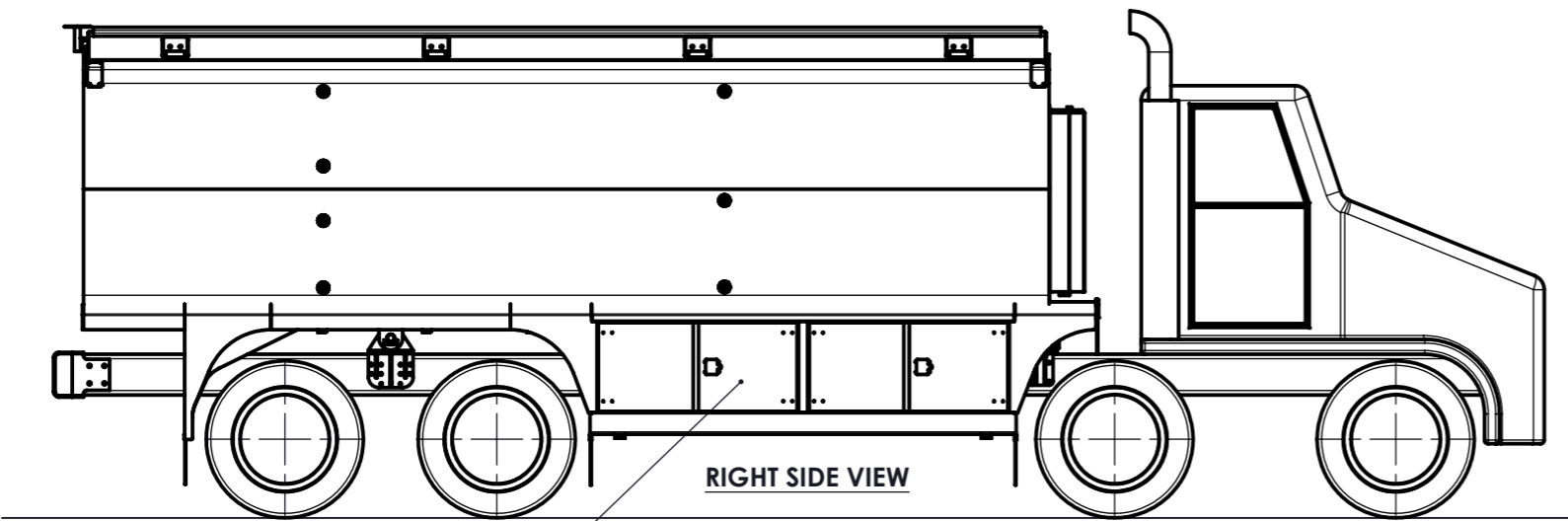
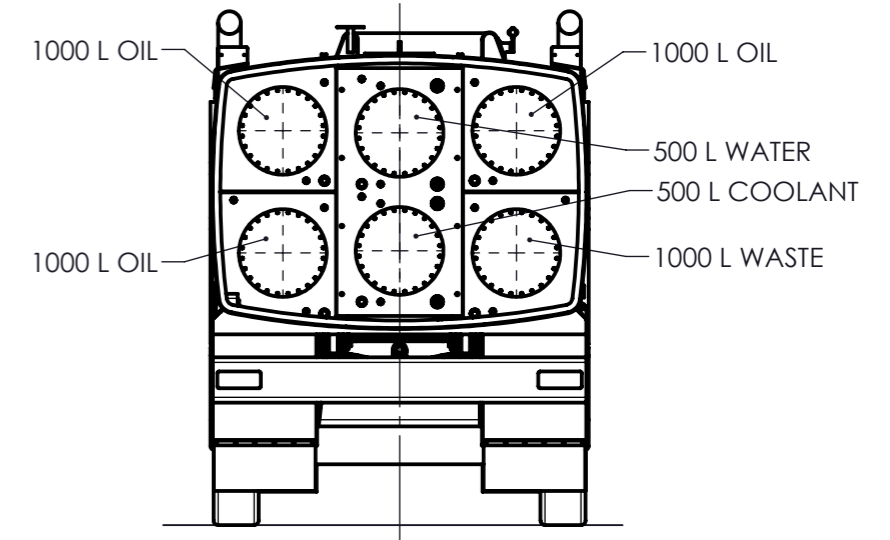

RIGHT SIDE VIEW

A	EJZ	INITIAL DESIGN	24/09/2009
REV.	BY	DESCRIPTION	DATE
DRAWING REVISION HISTORY			
DESIGN			

DO NOT SCALE - IF IN DOUBT ASK

THESE STANDARDS & SPECIFICATIONS APPLY U.N.O.			
TOLERANCES	AS NOTED	DRAWN TO AS1100 UNITS IN mm U.N.O.	
MATERIAL	AS NOTED	A3 1:50	
HARDNESS RANGE	AS NOTED	SCALE U.N.O. ©	
CALCULATED MASS	N/A	DRAWN EJZ 24/09/2009	
ACTUAL MASS	N/A	CHECKED XXX 1/07/2009	
SURFACE FINISH	AS NOTED	APPROVED XXX 1/07/2009	
PAINT	AS NOTED	<p>LESLIE CONSULTING PTY LTD 225 BRISBANE TERRACE GOONDA QLD 4300 AUSTRALIA PH: +617 3436 2500 FX: +617 3818 0036</p>	

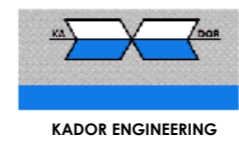

KADOR ENGINEERING

DESCRIPTION		SHEET
KENWORTH T408 8x4 SERVICE TRUCK - GENERAL ARRANGEMENT		1 OF 7
Drawing Number		INTERNAL REF No.
2860-000-00		JOB No 2860
REV		A3
		-01

THE DESIGN AND TECHNICAL INFORMATION DETAILED ON THIS DRAWING IS THE EXCLUSIVE PROPERTY OF LESLIE CONSULTING PTY LTD. IT IS ISSUED ON THE STRICT CONDITION THAT, EXCEPT WITH OUR WRITTEN PERMISSION, IT MUST NOT BE USED FOR ANY PURPOSE OTHER THAN ITS STATED PURPOSE OF ISSUE.